

EDM-MD Control Box

EDM-MD Control Box



No:	Description
1.	Power Input Plug in 200-240V AC
2. RUN / PRG Switch	Slide switch to change from RUN mode to PROGRAM mode
3. TEST / UP & SET Buttons	TEST Button - Used to check the basic function of the operator when servicing or installation. Activation signal for Test open cycle (RUN mode only) UP & SET Button - Used when in PROGRAM mode only. (To enter Programming mode: Slide switch from RUN to PROG.)
4. LED Display	LED Display is a visual display for the installer in order to correctly set up and operate MICOM EDM MD Operator. LED Display: LED1 : Function / Application, LED2 : Parameter Value Green LED : Power indicator Red LED : Sensor indicator (SS or SB)
5. SW4	SW1 : Opening direction SW2 : RS function (Ratchet or Flip Flop) SW3 : CE (Closed End) Output ON - Closed end output signal is given whilst door is open OFF - Closed end output signal is given whilst door is closed SW4 : E-lock (set OFF when E-lock is connected (YES))
6. Motor Plug	Connection of Motor to Control by Plug in
7. Sensor Harness	Connection of Sensor Harness to Control by Plug in
8. E-Lock	Relay Output (NO or NC) (DC 24V 300mA)
9. DC 24V	Output for E-Lock (can be used for sensors, as well.) (DC 24V 300mA)

Delivery

Delivery

MICOM EDM-MD Series - Supplied in formats as follows:

- > **EDM-MD 'COMPLETE OPERATOR'** consisting of: Base Rail, Cover, Control Box, Connection Harness, Motor Gear Box, Connection Terminal, End Covers, Tooth Belt, Belt Bracket Link Assembly, Belt Connection Single & Double Door, Belt Tightening / Idle Pulley Assembly, Hanger Roller Brackets x4 and Stopper x 2.
- > **COMPLETE OPERATOR** - Standard Rail Length: Single Leaf - 2100mm, Double leaf - 4200mm
- > **EDM-MD 'FULL KIT'** - (Without Rail & Cover) consisting of: Control Box, Connection Harness, Motor Gear Box, Connection Terminal, Tooth Belt (7M), Belt Bracket Link Assembly, Belt Connection Single & Double Door, Belt Tightening / Idle Pulley Assembly, Hanger Roller Brackets x4 and stopper x 2.
- > **RAIL & COVER** - (Material Only) - Standard Length: Single Leaf - 2100mm, Double leaf - 4200mm

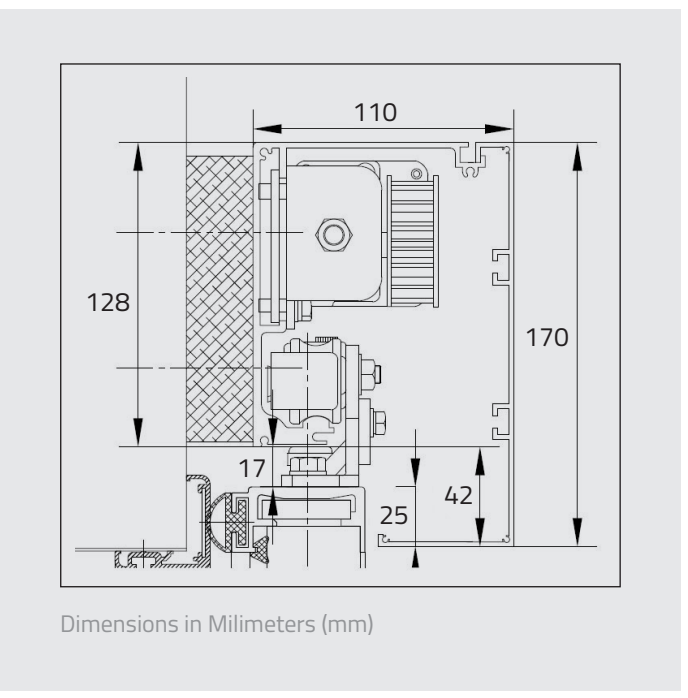

EDM-MD-S Motor Gear Box

EDM-MD-S Motor Gear Box

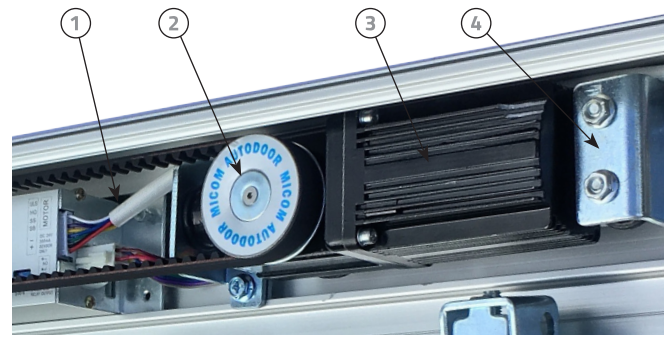

No:	Description
1.	Connection Harness to EDM MD Control Box
2.	Motor Pulley
3.	Brushless DC Motor
4.	Motor Mount Base with Vibration Proof Rubber

Specification

Model	MD-S-S	MD-S-D
Application	Single	Double
Door Weight (max)	100kg	100kg x2
Power Consumption	200 -240V AC, 0.7A (MAX)	
Power Output	24V DC, 300mA (for accessory only)	
Open Door Speed	Adjustable 160 - 500mm/s (11 steps adjustable)	
Close Door Speed	Adjustable 160 - 400mm/s (11 steps adjustable)	
Braking Adjust	0 - A value (11 steps adjustable)	
Open Door Timer	1 - 60sec (16 steps adjustable)	
Partial Open	35%, 50%, 65%, 80% (4 steps adjustable)	
Safety Obstruction	Closing travel: Safety return / Opening travel: Safety stop	
Motor	DC 24V / 55W Brushless	
Operating Temperature & Humidity	0°C - 50°C / 30% - 85%	



UK / European Office
The Grainger Suite // Regent Centre // Gosforth
Newcastle upon Tyne // NE3 3PF // United Kingdom
Telephone. +44 (0)191 233 6323
Email. info@micomautodoor.com

Head Office - Japan
6th Floor // Marutake-Honmachi Building 6-18
Honmachi 1-Chome Chuo-ku // Osaka 541-0053 // Japan
Telephone. +81 6 6265 1130
Facsimile. +81 6 6265 1132
Email. info@micomautodoor.com

100% Japanese Quality and Engineering
MICOM & NHN are registered trademarks and divisions of Kenwa Company Limited, Osaka, Japan

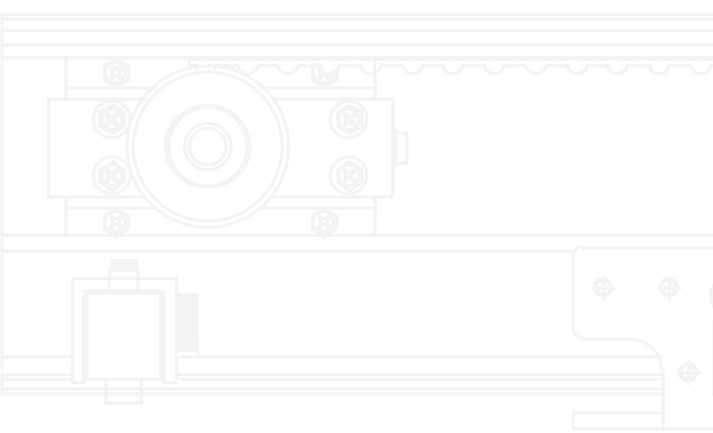

EDM MD-S

Automatic sliding door operator
Exceptional quality, economical prices



Introduction

EDM-MD Series is designed to provide a high quality, economical automatic sliding door solution for easy open and close operation. Offering variable function adjustment for single or double door leaves up to 100kg per leaf. Installation and set up is simple and achieved in several steps. Door stroke is memorized by simply pushing the RESET button one-time during initial installation or for servicing requirements. There is no need for the operator to re-learn each time the main power is turned on.

Automatic operation is upon sensor or switch activation with safety beam threshold safety input active when the doors are in operation. Together with many other functions available, operational parameters can be adjusted to suit each individual installation through the easily accessible LED visual display found on EDM-MD Control box face.

Connections for sensor and other inputs are located as either an independent input terminal on the rail or by adding MICOM Sensor and Battery Monitoring board (SMB) for EN16005 Compliance.

MICOM inbuilt safety features and quality components will ensure EDM-MD Series is safe and reliable, while providing you with assured long term service.

Main Features

- > Economical & Cost Effective Sliding Door Solution
- > Power input 200-240VAC
- > Door Capacity 100kg per leaf
- > Door Speed 500mm/s max
- > Memorized one time door stroke
- > Easily accessible sensor and threshold safety Inputs
- > 24V DC Power Output for Accessories
- > Safe & Long Term Operation Guaranteed
- > LED Digital Control Display
- > Simple Door Parameter Setting
- > Door Speed & Braking Adjustment
- > Energy Saving (% Open) Function
- > Delay Function for Electric Lock
- > Ratchet or Flip-Flop Function
- > Wide Parameter Adjustments

EN16005 Compliance

MICOM SMB is a SENSOR & BATTERY MONITORING SYSTEM which offers compliance with EN16005 across our range of EDM Series automatic sliding door operators. It is compatible with models EDM NII, GII/EZ & MD Series.

MICOM SMB is a modular system for enhanced automatic door safety. Simple to install, whilst offering added protection and multi-functional features which include:

- > Conforming to EN16005
- > Individual Sensor Monitoring & Safety
- > Battery Functions & Monitoring
- > Key Function Selector Switch (Locked / Exit / Automatic / Hold Open, plus Emergency - Anti Panic Open)
- > Individual Sensor Inputs & Wiring
- > LED Indicator (Mode & Error)
- > Emergency Open Input
- > 24VAC Power Input (Isolated Transformer)
- > Night Mode (Switch) Input
- > Secure E-Lock Functions

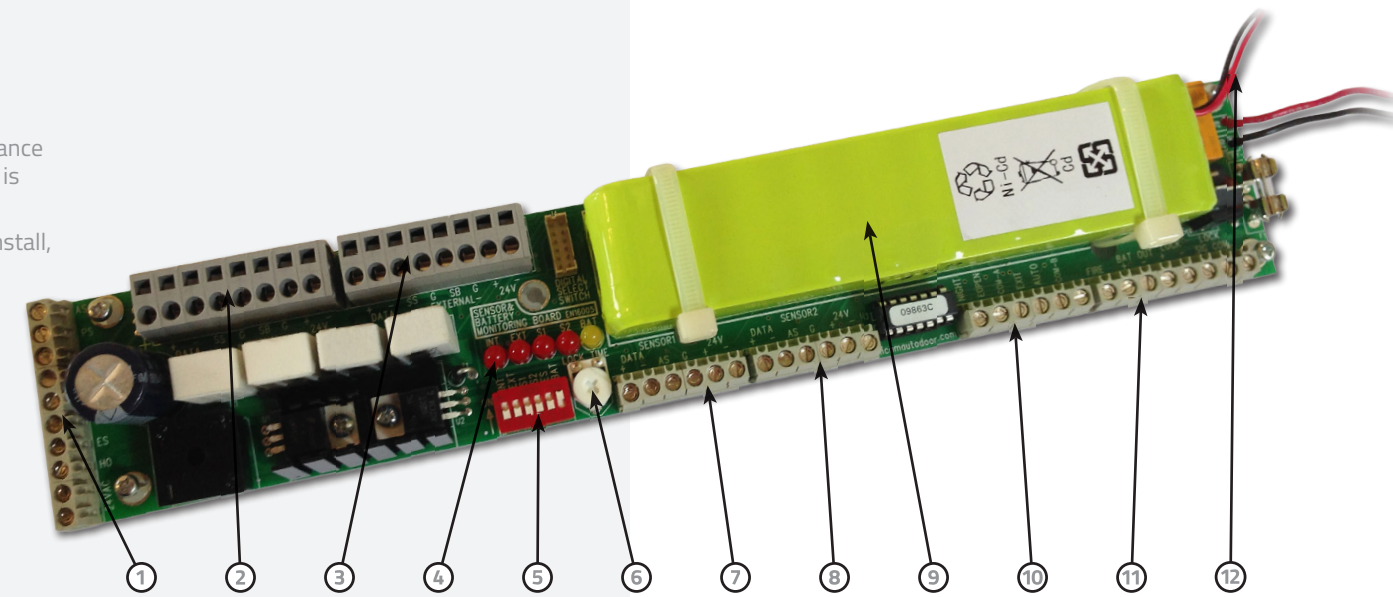

No:	Description
1.	SMB output to Control Box
2.	Internal Sensor Input
3.	External Sensor Input
4.	LED Error Indicator
5.	DIP Switch
6.	E-Lock Timer
7.	Side Screen Sensor Input 1
8.	Side Screen Sensor Input 2
9.	Battery Pack
10.	Selector Switch Input (4 wire)
11.	E-Lock & Battery Output
12.	Battery Connection

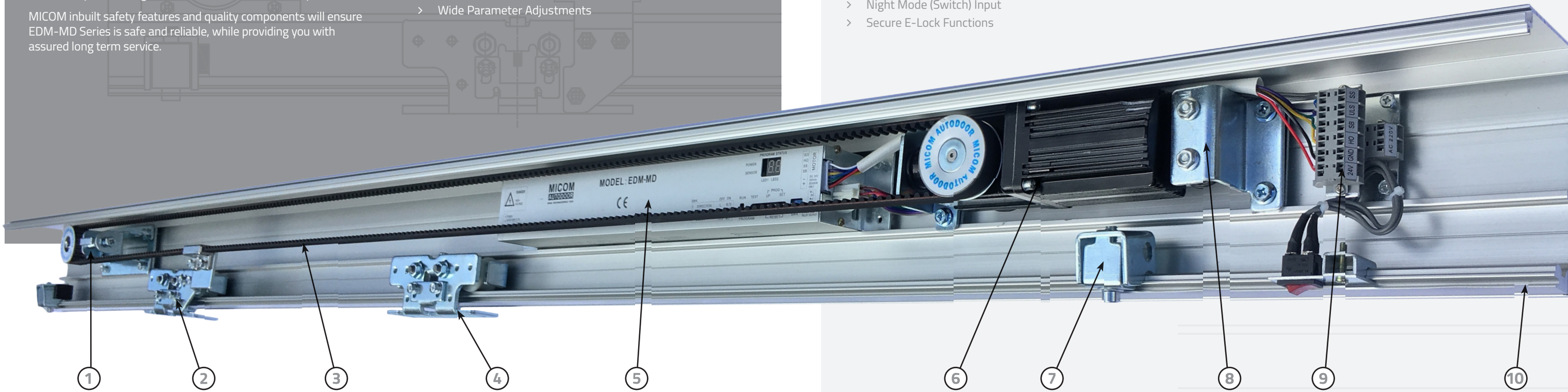

EDM-MD Complete Operator

No:	Description
1.	Belt Tightening / Idle Pulley Bracket Assembly
2.	Hanger Roller Bracket with Belt Bracket Link Assembly (Single Leaf)
3.	Tooth Belt
4.	Hanger Roller Brackets (Double Roller as standard)
5.	EDM MD Control Box
6.	EDM MD Motor Gear Box Assembly
7.	Door Stop
8.	Motor Mount Bracket with Vibration Proof Rubber
9.	Connection Terminal with Power On Off Switch
10.	Base Rail with Cover and Side Cover (Cover not shown)

EDM-MD together with **MICOM SMB** when used as a complete operator, complies with all new EU regulations (EN 16005) for enhanced automatic door safety. Designed for use with a new range of sensors such as BEA IXIO-S & Optex OA-Axis-T.

IXIO-S is an active infrared presence sensor. The tridimensional area of its infrared curtain protects the users from any contact with the doors. Adjustment is made easier with an LCD screen offering 10 different widths of curtains, to cover the full travel area of the door.



OA-AXIS-T Series based on active infrared technology. Developed as a combination sensor for threshold safety and activation, the OA-Axis T is in compliance with the latest European and local regulations as EN 16005 and DIN 18650, tested and approved by the German test organisation TÜV. Due to its variety in output options the OA-Axis series meets the requirements in various markets throughout Europe.



EDM-MD when used without SMB can also accept all current sensors available in the world market today, such as BEA Eagle & Optex OA-203C together with threshold safety beam protection.

EAGLE Series is a microwave sensor which detects movement. Utilising a planar antenna together with multi directional detection modes, the EAGLE offers high levels of stability and reliability. It is the solution for all types of automatic doors, irrespective of the surroundings utilizing K-band microwave technology.



OS-12C Safety Beam is an active infrared safety beam system. Its amplifier and sensor heads are designed for fast, simple installation while maintaining the highest standards of safety and reliability. Recognized by door professionals worldwide for its reliability and resistance to sunlight and other interference.



CE EN16005 Compliant

Accessories

MICOM Function Selector Switches offer several options of door control. As either a rotary knob or with a secure key, allows selection of 4 to 5 separate door modes. Economic in design, MICOM Function Selector are easy to install and operate. Supplied in a fire retardant black plastic mount box, with attractive cover design in white, our function selectors can be fitted to walls or aluminium frames alike.

Section Functions:

- > Position 1. Closed / Night
- > Position 2. Exit Only (Entry Only available as additional option)
- > Position 3. Automatic
- > Position 4. Hold Open

With Push Button (option) for Exit in case night function is selected. Finished complete with 3m Cable.



Door Profile Solutions - Various Fixed and Moving profile designs available without glass.

Glass Fittings



Glass Bracket - For 10mm glass door 90kg max / 1.2m width max & 12mm glass door 120kg max / 1.5m width max
Glass Clamp - For 10mm glass door 100kg max / 1.5m width max

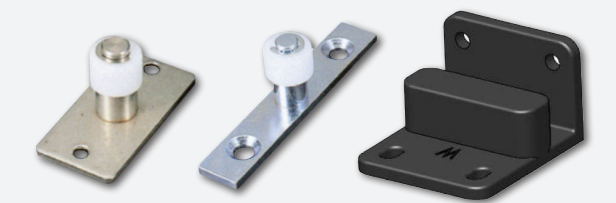

Floor Guide - Floor guides for framed and frameless glass doors available.